

SOUNDSTREAM
T E C H N O L O G I E S



**LIL'WONDER
LIL'WONDER4
Power Amplifiers**

**OWNER'S MANUAL
AND
INSTALLATION GUIDE**

SOUNDSTREAM
T E C H N O L O G I E S

11365 Sunrise Park Dr · Rancho Cordova · California 95742 USA
tel 916.351.1288 · fax 916.351.0414
rev DC -6/22/99

WWW.SOUNDSTREAM.COM

Congratulations

Thanks for buying Soundstream's **Lil' Wonder\Lil' Wonder4**. We have always been known for amazing high-end power plants, and to show our flexibility and versatility we make great equipment like this. Your new amp has been designed to give you the "most performance available in the smallest package possible." Hence the name **Lil' Wonder!** Pound for pound and inch for inch these are some of the strongest amps ever made.

The **Lil' Wonder\Lil' Wonder4** are the ideal amps for almost any configuration. They have the power to run front speakers, rear fill, a center channel, or even more importantly, giant subwoofers. Don't let their compact sizes fool you, you'll be amazed by the power. They have all of the technological advantages of their big Rubicon brothers, like a RUBI™ power supply and STACT™ architecture. To get the most performance out of your system, you'll need to read this entire manual. It is the only way to learn about all of the Lil' Wonders' capabilities and features. Please keep this manual and your sales receipt for future reference.

These gutsy amplifiers, like all Soundstream amplifiers, are the result of American innovation and the highest quality control standards. When properly installed, it will provide you with many years of listening pleasure. Just in case someone "borrows" your amplifier with no intention of returning it, fill in the blanks below and stash them away in your permanent records. It will help to protect your investment. Once you have done that, you're ready to rock. So hook it up, crank it up, and be amazed by your new **Lil' Wonder\Lil' Wonder4**.

Model and Serial # _____

Dealer's Name _____

Date of Purchase _____

Installation Shop _____

Installation Date _____

CAUTION!

Prolonged listening at high levels may result in hearing loss. Even though your new Soundstream Rubicon amplifier sounds better than anything you've ever heard, exercise caution to prevent hearing damage.

Table of Contents

Design Features	p 4-5
Lil' Wonder Amplifier Diagram	p 6-7
Lil' Wonder4 Amplifier Diagram	p 8 - 9
Crossover & Hawkins Adjustments.. ..	p 10
Hawkins Bass Control™ Theory and Use	p 11
Installation: Speaker Output Modes	p 12
Installation: Wiring and Diagram.....	p 13 - 14
Installation: Mounting	p 15
Installation: Level Setting and Front Spoiler.	p 16
Protection Circuitry and Troubleshooting	p 17
Service	p 18
Specifications	p 18
Notes	p 19

Design Features

- **RUBI™ Power Supply** (Rapid-Use Branched Impulse) Our new power supply eliminates “power sags” during low frequency reproduction by rapidly increasing the duty cycle, stabilizing the power supply and allowing it to deliver the power required when reproducing low frequencies. Also, greater reserve gate power is now stored for low voltage conditions that occur during extreme conditions.
- **STACT™** (Stabilized Apex Current Topology) Reduces power supply stress by 50%. Use of inverted channels usually degrades the stereo image due to phase reversal of even order harmonic distortion that occurs between the inverted channels. In the STACT design inversion is done at the power amplifier drive stage. Since the fully symmetrical power amplifier produces no even harmonic distortion itself and all preamp circuitry (which does produce even harmonics) is run completely in phase, no even harmonic distortion phase reversal occurs.
- **Trident™ Protection** Three types of protection for RUBICON amplifiers:
 - 1 Output protection against short circuits or improper loads
 - 2 Ground fault detection shuts down the amplifier when a significant (5 volt or greater) voltage fluctuation occurs between audio ground and battery ground.
 - 3 Thermal protection will shut the amplifier down in extreme thermal conditions.
- **Hawkins Bass Control** Provides focused subwoofer boost and routes wasted subsonic power to the audible bandwidth. The **Lil' Wonders** contain the fixed Hawkins Bass Control which allows you to boost bass 6dB at 45Hz. A built-in subsonic filter at 45Hz helps protect the speakers.
- **Harmonic Bass Alignment™** The 2nd and 3rd order harmonic peaks are critically aligned to fundamental peaks at low frequencies. This produces tighter, more accurate bass reproduction.

- **Drive Delay II Muting™** Amplifier section now powers up 2 - 3 seconds after power supply, eliminating turn on pops. Turn off process is reversed. Amplifier section turns off first, followed by power supply.
- **Dynamically Optimized Power Grid™** Power grid is now evenly distributed between primary and secondary power supplies, providing greater dynamics and improved RF filtering.
- **Chassisink™** All transistors are sandwiched between the circuit board and the heatsink to provide cool efficient amplifier operation in a smaller package.
- **Continuously Variable Lowpass Crossover Networks (Lil' Wonder4)** 12dB/oct Lowpass crossover variable from 55 to 220Hz.
- **Built-in Staggered S.I.P. Crossover Networks** Built-in two-way electronic crossover is designed to send either high or low pass information to the amplifier with a 12dB/oct slope (Highpass only on the **Lil' Wonder4**).
- **Flexible Input Level Control** 200mV to 5V input sensitivity. Stereo level control allows user to optimize system level control.
- **Symmetrical Discrete Balanced Class A Drive Boards** Auto-adjusts for linear performance in low impedance loads.
- **Removable Front Spoiler** Allows for stealth installation of RCA, Speaker and Power wiring.

Key To Callouts

- Power LED** - Indicates amplifier power.
- Subsonic, Hawkins Bass Control, H.P. XOVER Switch** - Selectable high pass filter frequency range. Select "SUB SONIC" to engage the Sub Sonic filter at 13Hz with no boost. Select "Hawkins Bass Control" to engage the Sub Sonic filter at 45 Hz with a +6dB boost. Select "H.P. XOVER" to engage the amplifier's high pass filter at 45Hz or 150Hz (depending on S.I.P.'s) for running satellite speakers.
- Low Pass XOVER Switch** - Selectable low pass filter for driving subwoofers at 90Hz. Note: Do not have the "L.P. XOVER" and the "H.P. XOVER" engaged at the same time except for bandpass operation.
- MONO/ST Switch** - Select "MONO" for bridged mono operation with a single input signal (right channel only). Select 'ST' for normal stereo operation.
- FUSE** - Main power supply fuse. *Warning: Replace on/y with the same value fuse!*
- +12V** - Connected to a fuse or circuit breaker, then to the battery's positive terminal.
- REMOTE** - Remote turn-on input from the head unit. Accepts +12V.
- GND** - Main ground connection. Bolt to a clean chassis point in the vehicle.
- Speaker Connection Terminal** - Speaker connections for channels 1&2.
- Input Levels** - Stereo input level control.
- RCA Inputs** - Right and Left channel RCA inputs.
- Crossover S.I.P.'s** - Crossover frequency settings for amplifier.

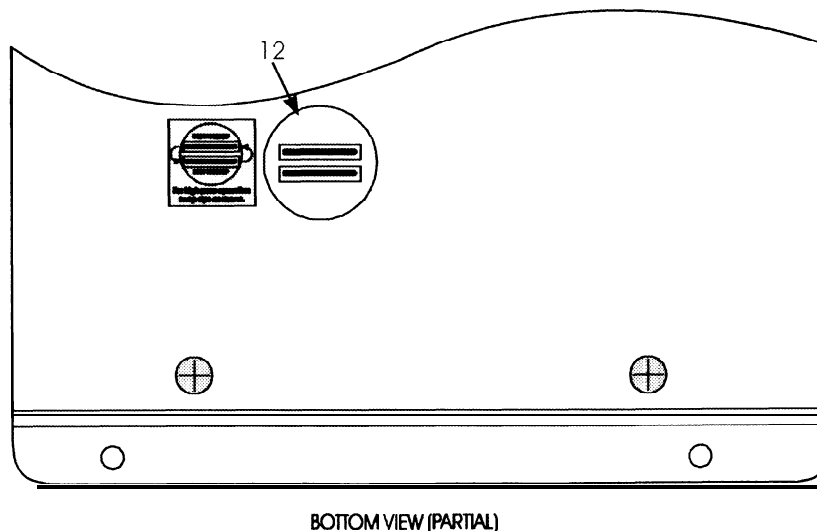
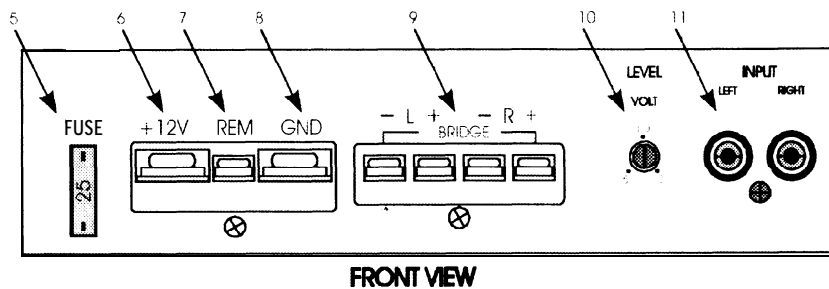
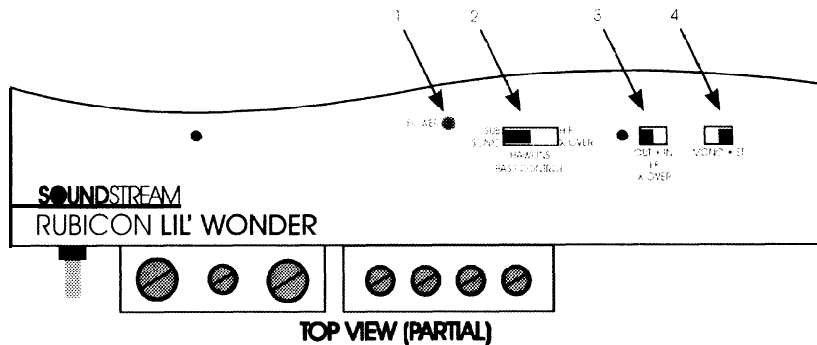

Key To Callouts

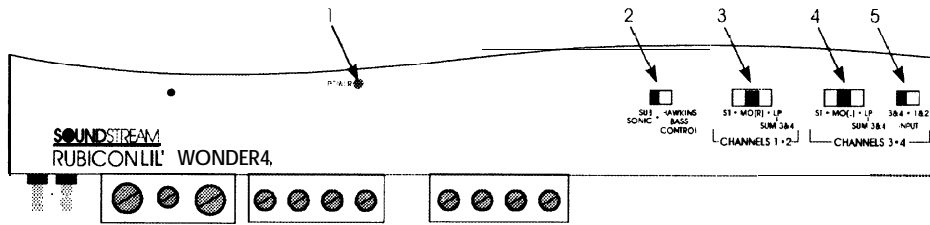

TOP VIEW (PARTIAL)

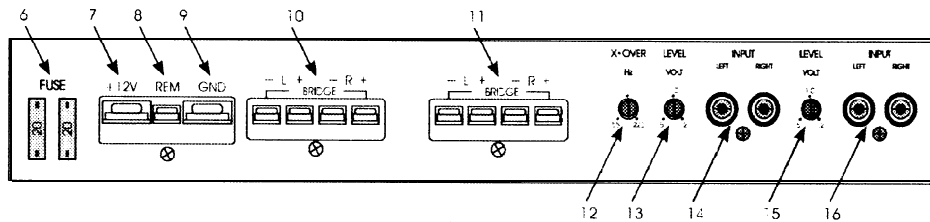

FRONT VIEW

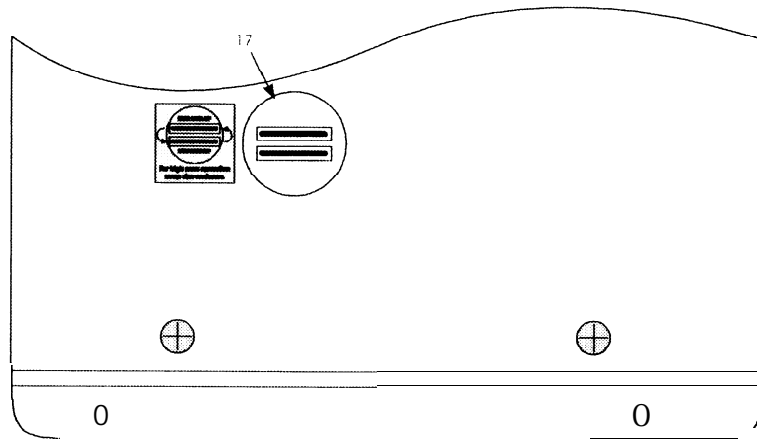

BOTTOM VIEW (PARTIAL)

1. **Power LED** - Indicates amplifier power.
2. **Subsonic / Hawkins Bass Control Switch** - Select 'Subsonic' to engage the Subsonic filter at 13Hz. Select "Hawkins Bass Control" to engage the +6dB boost @ 45 Hz for the lowpass channel.
3. **ST/MO(R)/LP Switch** - "ST" for normal stereo operation. "MO" for bridged mono operation with a single input signal (right input only). "LP" for low pass bridged mono operation with input from channels 3&4.
4. **ST/MO(L)/LP Switch** - "ST" for normal stereo operation. "MO" for bridged mono operation with a single input signal (left input only). "LP" for low pass bridged mono operation with input from channels 3&4.
5. **Input Selection Switch** - Selectable inputs from internal (channels 1&2) or external (channels 3&4).
6. **Fuse** - Main power supply fuse. Warning: Replace on/y with the same value fuse!
7. **+12V** - Connected to a fuse or circuit breaker, then to the battery's positive terminal.
8. **Remote** - Remote turn-on input from the head unit. Accepts +12V.
9. **GND** - Main ground connection. Bolt to a clean chassis point in the vehicle.
10. **Speaker Connection Terminal** - Speaker connections for channels 1&2.
11. **Speaker Connection Terminal** - Speaker connections for channels 3&4.
12. **Low Pass Filter Control Adjustment** - Crossover frequency control for the internal low pass filter.
13. **Input Levels** - Stereo input level control for channels 1&2.
14. **RCA Inputs** - Right and Left channel RCA inputs for channels 1&2.
15. **Input Levels** - Stereo input level control for channels 3&4.
16. **RCA Inputs** - Right and Left channel RCA inputs for channels 3&4.
17. **Crossover S.I.P.'s** - Crossover frequency settings for amplifier.

Crossover & Hawkins Bass Control Adjustments

CROSSOVER

In most car audio installations, there is a tendency for a "midbass boom." Because of their interior dimensions, most cars will resonate or ring at these midbass frequencies. If we design the system so there is reduced output information in this region, the final response is very smooth and natural sounding.

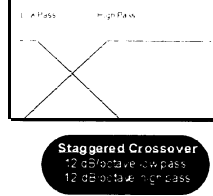

CHANGING FREQUENCIES

The Lil' Wonder comes with a 90Hz Low Pass S.I.P. and a 45Hz Hawkins and High Pass S.I.P. (Series In-line Package resistor network) If you are using this amplifier in the Low Pass Configuration, you will not need to change the S.I.P. crossover. If you are using the amplifier in a High Pass configuration we recommend that you use a higher frequency (150Hz) for your crossover. In order to receive a higher crossover point, remove the factory Low Pass S.I.P. (The S. I. P. with the white dot), and the factory High Pass/Hawkins S.I.P. out of the amplifier. Place the S.I.P. with the white dot in the socket for High Pass/Hawkins. This will give a High Pass frequency of 150Hz. Then place the remaining S.I.P. in the Low Pass socket. Make Sure That the Low Pass Crossover is NOT Engaged while the High Pass crossover is engaged, unless a bandpass x-over is desired. If you want to use a frequency other than the factory pre-set frequencies follow the chart to the left or the formula below to select your own crossover points.

The Lil' Wonder4 uses the same S.I.P.'s for High Pass (factory set at 150 Hz) and Hawkins as the Lil' Wonder. However, the Low Pass is adjusted using a 12dB/oct variable crossover that has a range of 55 to 220 Hz. On either amplifier a full range signal can be achieved by removing the S.I.P.'s entirely.

SIP (K Ω)	LP (Hz)	HP (Hz)
180	NA	22
120	NA	26
82	NA	33
62	NA	39
47	23	47
43	25	50
30	36	66
22	49	86
15	71	120
12	89	146
8.2	130	208
4.7	228	353
3.3	324	498
2	535	813

NOTE: The following formulas must be used to determine values in creating custom resistor networks.
 The Low Pass frequency is equal to $1/0.000157 \times R$ where R is the individual resistor value or $1/0.000157 \times R$ ohms = X Hz. Example: $1/0.000157 \times 12,000 = 89$ Hz
 The High Pass frequency is equal to $1/600,000 \div$ divided by the individual resistor value plus 13, or $(1/600,000 / R \text{ ohms}) + 13 = X$ Hz. Example: $(1/600,000 / 12,000) + 13 = 146$ Hz
 To make a custom S.I.P. use 4 identical valued resistors of 1/2 watt minimum to create. See the diagram of this S.I.P. for more information.

Hawkins Bass Control - Theory and We

Hawkins Bass Control (fixed) is a unique subwoofer control circuit included with the Soundstream Lil' Wonder/Lil' Wonder4 amplifiers. It is capable of removing subsonic energy in program material below 45 Hz at 12 dB/Octave, while boosting subwoofer frequencies by +6dB. Once you engage the switch, you engage a subsonic (High Pass) filter at 45 Hz, with a +6dB boost at 45 Hz.

Application

Subwoofer drivers in general have excellent power handling characteristics over their operational bandwidth. This bandwidth is determined by many factors, including driver design, and enclosure type. It is possible to overdrive any subwoofer driver by sending powerful signals outside of its operational bandwidth. These potentially damaging signals can be removed by adding a subsonic filter. Figure 1 shows the effectiveness of the Hawkins Bass Control on woofer excursion in a vented enclosure. The woofer travels 7.5 mm at 10 Hz. With Hawkins Bass Control properly adjusted, this excursion can be reduced to less than 1 mm. This is of great benefit to lowering woofer distortion and increasing output.

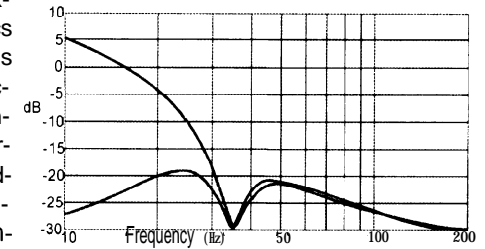

FIG. 1 Limited Excursion

With Soundstream's Hawkins Bass Control, the boost and frequency control can provide the "tailoring" needed for any type of "assisted" design and any woofer in any type of installation.

INSTALLATION STEP 1

SELECTING THE SPEAKER OUTPUT MODE

The RUBICON Lil' Wonder\Lil' Wonder4 amplifiers have the ability to operate in any one of the following modes:

Stereo (STACT / Mixed Mono): Use this mode for either stereo operation (left and right channels) or for Mixed Mono operation (stereo left and right channels plus bridged mono for a subwoofer).

Bridged Mono: Use this mode to get a bridged mono output while using only the right channel input and gain control (for use with a singular mono input).

Please follow the wiring schemes below for the correct operation:

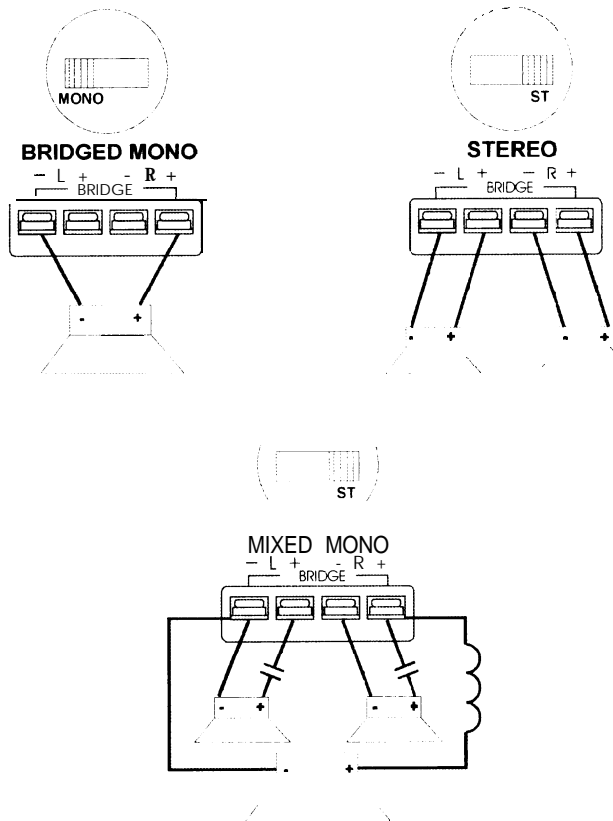

INSTALLATION STEP 2

WIRING

POWER AND GROUND

To ensure maximum output from your RUBICON Lil' Wonder\Lil' Wonder4 amplifiers, use high quality, low-loss power and ground cables and connections. The Lil' Wonder\Lil' Wonder4 amplifiers will accept up to 8 gauge power and ground cables. Determine from the chart below the minimum gauge power and ground wire for your application.

	upto 10'	up to 20'
Lil' Wonder	8 or 10 gauge	8 gauge only
Lil' Wonder4	8 or 10 gauge	8 gauge only

CIRCUIT BREAKERS AND FUSES

EXTERNAL

Like all audio components, the Lil' Wonder\Lil' Wonder4 must be fused near the battery. A fuse or circuit breaker must be located within 18" of the battery. This will prevent a fire in the event of a shorted cable. See the chart below to determine the correct fuse value.

INTERNAL

The Lil' Wonder\Lil' Wonder4 amplifiers are fused with automotive-type fuses. In the event of a blown power supply fuse, replace with the correct value fuse found in the chart below. **Never replace the fuse with a higher value than what is supplied. This may result in amplifier damage and will void the warranty!**

RUB/CON Amplifier Fuse Values

	Amplifier Fuse	Battery Fuse / Circuit Breaker
Lil' Wonder	25 amp automotive	30 amp
Lil' Wonder4	(2) 20 amp automotive	40 amp

REMOTE TURN-ON

Connect the "Remote" line to the turn-on lead from the source unit. When +12 Volts is received, the amplifier will turn on.

WIRING cont'd

SIGNAL CABLE

Use a high quality cable that will be easy to install and has minimal signal loss to guarantee optimum performance.

SPEAKER CABLE

The Lil' WonderLil' Wonder4 amplifiers will accept up to 12 gauge speaker cable. Use a high quality, flexible, multi-strand cable for best performance and longevity.

SAMPLE WIRING DIAGRAM

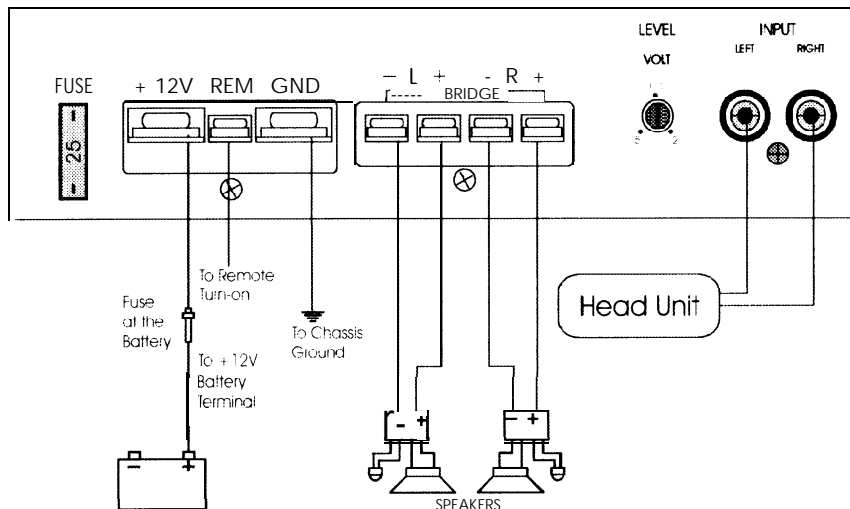

INSTALLATION STEP 3

INSTALLATION AND MOUNTING

AMPLIFIER LOCATION

The Lil' WonderLil' Wonder4 amplifiers employ highly efficient circuitry, a custom-engineered heat sink, and a unique Chassisink construction to maintain lower operating temperatures. Additional cooling may be required if the amplifier is located in a tightly confined area or when driving especially low impedance loads at extremely high levels.

When mounting the amplifiers, they should be securely mounted to either a panel in the vehicle or an amp board or rack that is securely mounted to the vehicle. The mounting location should be either in the passenger compartment or in the trunk of the vehicle, away from moisture, stray or moving objects, and major electrical components. To provide adequate ventilation, mount the amplifier so that there are at least two inches of freely circulating air above and to the sides of it.

MOUNTING THE AMPLIFIER

- Using the amplifier as a template, mark the holes on the mounting surface.
- Remove the amplifier and drill the holes for the mounting screws.
- Secure the amplifier to the mounting surface using the supplied hardware.

WIRING

- Run and connect the audio signal and remote turn-on cables to the amplifier from the source unit.
- Carefully run the positive cable from the amplifier to a fuse or circuit breaker within 18" of the battery.
- Connect the fuse or circuit breaker lead to the battery. Leave the circuit breaker off or the fuse out until everything is bolted down.
- Secure the ground cable to a solid chassis ground on the vehicle. It may be necessary to sand paint down to raw metal for a good connection.
- Double check each and every connection!
- Re-connect the fuse or circuit breaker.

POWER UP

Power up the system, there may be a 2-3 second delay from the time the source unit is turned on to the time that the amplifier turns on, which is normal. Once the amplifier LED is on and the source unit is playing, you should have sound coming from the speakers.

INSTALLATION STEP 4

LEVEL SETTING

The input levels are adjusted by means of the stereo channel input level control located on the front of the amplifier.

In the ideal situation, all components in the audio system reach maximum undistorted output at the same time. If you send a distorted signal to an amplifier, it is simply going to amplify distorted information. The same holds true if an outboard processor or crossover begins to distort before you have maximum output from the amplifier. By setting all components to reach clipping at the same time, you can maximize the output of your system. For the RUBICON amplifiers, follow these steps for setting the input levels:

1. Turn the amplifier's input level to minimum position (counter-clockwise).
2. Set the source unit volume to approximately $3/4$ of full volume.
3. While playing dynamic source material, slowly increase the amplifier's input level until a near maximum undistorted level is heard in the system.

FRONT SPOILER

Once the amplifier is installed and the proper levels set, place the front spoiler in position, and bolt it on using the supplied hardware.

Trident Protection Circuitry

Your Lil' Wonder/Lil' Wonder4 amplifier is protected against both overheating and short circuits by means of main power supply fuses and the following circuits:

- ◆ Speaker output protection
- ◆ Ground fault protection
- ◆ A failsafe thermal protection circuit

NOTE: If you experience blown main power supply fuses, it is likely that the amplifier is seeing a dead short, either in the speaker wire or in the speaker itself. Rectify the problem before blowing multiple fuses! DO NOT increase values beyond the original fuse value! Doing so will void your warranty and may damage your amplifier.

Troubleshooting

PROBLEM	CAUSE
No Sound and power LED is not lit	<ol style="list-style-type: none"> 1. No power or ground at the amp 2. No remote turn-on signal 3. Blown fuse near the battery
No sound, power LED is lit	<ol style="list-style-type: none"> 1. No signal input 2. Speaker or leads may be shorted 3. Speaker leads may be referenced to ground
Repeatedly blow amp fuse; frequent activation of Trident protection or Smart Power Supply Circuit	<ol style="list-style-type: none"> 1. Speaker or leads may be shorted 2. Amplifier load may be too low 3. Verify adequate amp ventilation
Very little output, or output is muffled	Make sure that <i>both</i> the L.P. and the H.P. crossovers <i>aren't</i> engaged

Service

Your Soundstream RUBICON amplifier is protected by a limited warranty. Please read the enclosed warranty card for details and send it in.

Notes

Specifications

Power (4 ohm, 12.6v)	Lots!
Power (2 ohm, 12.6v)	More!
Power (2 ohm, 14.4v)	Even more!
Power (4 ohms bridged, 14.4V)	Huge!
Maximum rated power	NC-1 7
Crossover	Up and Down
Damping	Wet, very wet
Frequency response	Flatter than a board
Color Factor	Blue
Hawkins Bass Control	2 settings: Bass! And More Bass!
Input sensitivity	Don't worry, you can't offend it
Piercings	Forty
Shape bias	100%
Signal to Noise	Foghorn to a dead monkey
Stereo separation	Legally, but still see each other on Fridays
THD	You can't hear it
Dimensions	Lil' Wonder: 36" x 24" x 36" (just kidding, 7" x 11 3/8" x 2 1/4")
	Lil' Wonder4: 44" x 24" x 24" (just kidding, 11" x 11 3/8" x 2 1/4")